

# INSTRUCTION MANUAL

## RA 55 RACK ADAPTER

### RACK ADAPTER FOR MST SERIES POWER MODULES

KEPCO INC.  
An ISO 9001 Company.

### MODEL RA 55 RACK ADAPTER

ORDER NO. <b>M441980</b>	REV. NO. <b>2</b>
--------------------------	-------------------

#### IMPORTANT NOTES:

- 1) This manual is valid for the following Model and associated serial numbers:

MODEL	SERIAL NO.	REV. NO.
-------	------------	----------

- 2) A Change Page may be included at the end of the manual. All applicable changes and revision number changes are documented with reference to the equipment serial numbers. Before using this Instruction Manual, check your equipment serial number to identify your model. If in doubt, contact your nearest Kepco Representative, or the Kepco Documentation Office in New York, (718) 461-7000, requesting the correct revision for your particular model and serial number.
- 3) The contents of this manual are protected by copyright. Reproduction of any part can be made only with the specific written permission of Kepco, Inc.

Data subject to change without notice.

©2000, KEPSCO, INC  
P/N 243-0853



KEPCO, INC. • 131-38 SANFORD AVENUE • FLUSHING, NY. 11352 U.S.A. • TEL (718) 461-7000 • FAX (718) 767-1102  
email: [hq@kepcopower.com](mailto:hq@kepcopower.com) • World Wide Web: <http://www.kepcopower.com>

## **Conditions of Conformance Rack Adapter products (EN61010-1)**

**When this product is used in applications governed by the requirements of the EEC, the following restrictions and conditions apply:**

- 1. For European applications, requiring compliance to the Low Voltage Directive, 73/23/EEC, this Rack Adapter is considered a component, designed for "built in" applications. Because it is incomplete in construction, the end product enclosure must provide for compliance to any remaining electrical safety requirements and act as a fire enclosure. (EN61010-1 Cl. 6, Cl. 7, Cl.8, Cl. 9 and EN61010-1 annex F)**
- 2. This Rack Adapter is designed for stationary installation, with mains power applied via a detachable power supply cord or via direct wiring to the source power terminal block.**
- 3. This Rack Adapter, when properly installed, is considered a Class 1 (earthed) product, and as such depends upon proper connection to protective earth for safety from electric shock. (EN61010-1 Cl. 6.5.4)**
- 4. This product is intended for use as part of equipment meant for test, measurement and laboratory use, and is designed to operate from single phase, three wire power systems. This equipment must be installed within a suitably wired equipment rack, utilizing a three wire (grounded) mains connection. See wiring section of this manual for complete electrical wiring instructions. (EN61010-1 Cl. 6.5.4 and Cl.6.10.1)**
- 5. This power supply has secondary output circuits that are considered hazardous, and which exceed 240 VA at a potential of 2V or more.**
- 6. The output wiring terminals of this power supply has not been evaluated for field wiring and, therefore, must be properly configured by the end product manufacturer prior to use.**
- 7. For complete circuit protection of the end product, as well as the building wiring, it is required that a primary circuit protection device be fitted to the branch circuit wiring. (EN61010-1 Cl. 9.6.2)**
- 8. When installed with other components and/or power supplies, hazardous voltages may be present within during normal operation. All operator adjustments are made via externally accessible switches, controls and signal lines as specified within the individual power supply operating instructions. There are no user or operator serviceable parts within this product enclosure. Refer all servicing to qualified and trained Kepco service technicians.**

## Declaration of Conformity

Application of Council directives: **73/23/EEC (LVD)**  
**93/68/EEC (CE mark)**

Standard to which Conformity is declared:

**EN61010-1:1993 (Safety requirements for electrical equipment for measurement, control and laboratory use)**

Manufacturer's Name and Address: **KEPCO INC.**  
**131-38 SANFORD AVENUE**  
**FLUSHING, N.Y. 11352 USA**

Importer's Name and Address:

**REPRESENTATIVE COPY**

Type of Equipment: **Rack Adapter**

Model No.: **[PRODUCT MODEL NUMBER]**

Year of Manufacture:

I, the undersigned, declare that the product specified above, when used in conjunction with the conditions of conformance set forth in the product instruction manual, complies with the requirements of the Low Voltage Directive 73/23/EEC, which forms the basis for application of the CE Mark to this product.

Place: **KEPCO Inc.**  
**131-38 Sanford Ave.**  
**Flushing, N.Y. 11352 USA**

**Saul Kupferberg**  
(Full Name)

Date: \_\_\_\_\_

**VP OF SALES**  
(position)



# SAFETY INSTRUCTIONS

## 1. Installation, Operation and Service Precautions

This product is designed for use in accordance with EN 61010-1 and UL 3101 for Installation Category 2, Pollution Degree 2. Hazardous voltages are present within this product during normal operation. The product should never be operated with the cover removed unless equivalent protection of the operator from accidental contact with hazardous internal voltages is provided:



There are no operator serviceable parts or adjustments within the product enclosure. Refer all servicing to trained service technician.



Source power must be removed from the product prior to performing any servicing.



This product is factory-wired for the nominal a-c mains voltage indicated on the rating nameplate located adjacent to the source power connection on the product's rear panel. To reconfigure the product input for other nominal mains voltages as listed herein, the product must be modified by a trained service technician.

## 2. Grounding

This product is a Class 1 device which utilizes protective earthing to ensure operator safety.



The PROTECTIVE EARTHING CONDUCTOR TERMINAL must be properly connected prior to application of source power to the product (see instructions on installation herein) in order to ensure safety from electric shock.



PROTECTIVE EARTHING CONDUCTOR TERMINAL - This symbol indicates the point on the product to which the protective earthing conductor must be attached.



EARTH (GROUND) TERMINAL - This symbol is used to indicate a point which is connected to the PROTECTIVE EARTHING TERMINAL. The component installer/ assembler must ensure that this point is connected to the PROTECTIVE EARTHING TERMINAL.

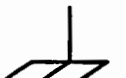

CHASSIS TERMINAL - This symbol indicates frame (chassis) connection, which is supplied as a point of convenience for performance purposes (see instructions on grounding herein). This is not to be confused with the protective earthing point, and may not be used in place of it.

## 3. Electric Shock Hazards

This product outputs hazardous voltage and energy levels as a function of normal operation. Operators must be trained in its use and exercise caution as well as common sense during use to prevent accidental shock.



This symbol appears adjacent to any external terminals at which hazardous voltage levels as high as 500V d-c may exist in the course of normal or single fault conditions.



This symbol appears adjacent to any external terminals at which hazardous voltage levels in excess of 500V d-c may exist in the course of normal or single fault conditions.



# TABLE OF CONTENTS

SECTION	PAGE
<b>SECTION 1 - DESCRIPTION</b>	
1.1      General.....	1
1.2      Electrical.....	2
1.3      Mechanical.....	2
1.4      Accessories.....	2
 <b>SECTION 2 - CONFIGURING THE RA 55 RACK ADAPTER</b>	
2.1      Input Power .....	6
2.1.1      General.....	6
2.1.2      Safety Grounding.....	6
2.1.3      Source Power Connections.....	6
2.2      Load Connections .....	7
2.3      Control Signal Connections.....	7
2.4      Slot 9 Configuration.....	7

## LIST OF FIGURES

FIGURE	TITLE	PAGE
1	Kepeco Model RA 55 Rack Adapter .....	1
2	RA 55 Backplate Assembly.....	2
3	Controller to Power Module Interface .....	3
4	RA 55 Interconnections and Input/Output Pin Connections.....	4
5	Mechanical Outline Drawing of the RA 55 Rack Adapter.....	5
6	Load Connector Assembly Procedure .....	8

## LIST OF TABLES

TABLE	TITLE	PAGE
1	Accessories .....	3

## 1.2 ELECTRICAL

The rack adapter contains a PCB backplane whose connectors facilitate hot-swapability. Dual a-c input terminal blocks (J10 and J11) on the backplate assembly (Figure 2) distribute input power to nine PCB-mounted a-c input/control bus power connectors (P1 - P9) as shown in Figure 4. Terminal block J10 provides input power slots 1 through 4; terminal block J11 provides input power to slots 1 through 9. Two-wire IEEE 1118 control bus data is supplied to the nine a-c input/control bus power supply connectors via two 9-pin (six pins are not used) connectors, J12 and J13 on the backplate assembly. The utilized pins of the two IEEE 1118 control bus connectors are paralleled, facilitating "daisy chain" control bus configurations. A shield connection is routed to connector P9 for grounding within the controller when a controller is installed; otherwise this connection is not used.

The d-c output connectors of the MST power supplies installed in the rack adapter are accessed via connector extenders (J1 - J9) mounted on the backplate assembly.

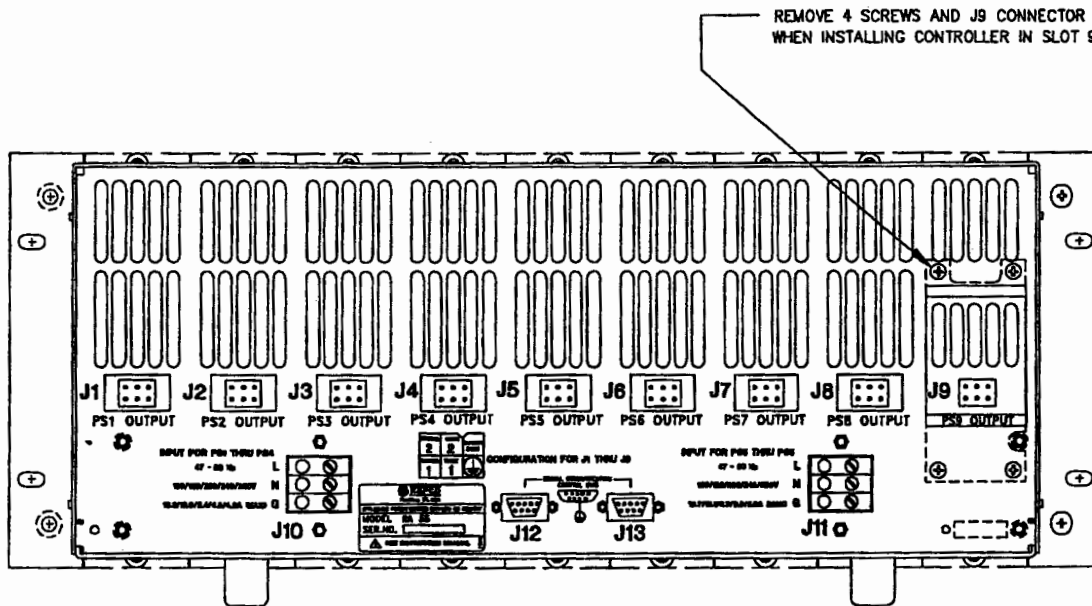

FIGURE 2. RA 55 BACKPLATE ASSEMBLY

## 1.3 MECHANICAL

The rack adapter is pre-drilled to accept chassis slides. It is equipped with four metal foot attachments, rack adapter handles, and mounting ears. The rack adapter can use 18-inch (457.2 mm) Jonathon Model 110-QD-18-2 chassis slides. The rack adapter can be equipped with optional 1/9 rack blank filler panels (Kepco Model RFP 55-1) if the full complement of nine power supplies is not utilized.

Mechanical dimensions, material, and finish of the Kepco Model RA 55 Rack Adapter are provided in Figure 5.

## 1.4 ACCESSORIES

Table 1 lists the accessories provided with the RA 55 Rack Adapter. A controller and up to 27 MST, MAT or MBT Power Modules can be connected in a daisy chain configuration as shown in Figure 3. The last power module control bus outlet (in the daisy chain) must be terminated with



## SECTION 1 - DESCRIPTION

### 1.1 GENERAL

The Kepco Model RA 55 Rack Adapter (Figure 1) is designed for the installation of Kepco MST Series Power Supplies into a standard 19-inch rack. Each rack adapter can accommodate a maximum of nine power supplies, or eight power supplies and a communication bus controller (Kepco Model MST 488-27) installed in slot 9. The RA 55 has a removable plate at the rear of slot 9 to allow for the controller connector.

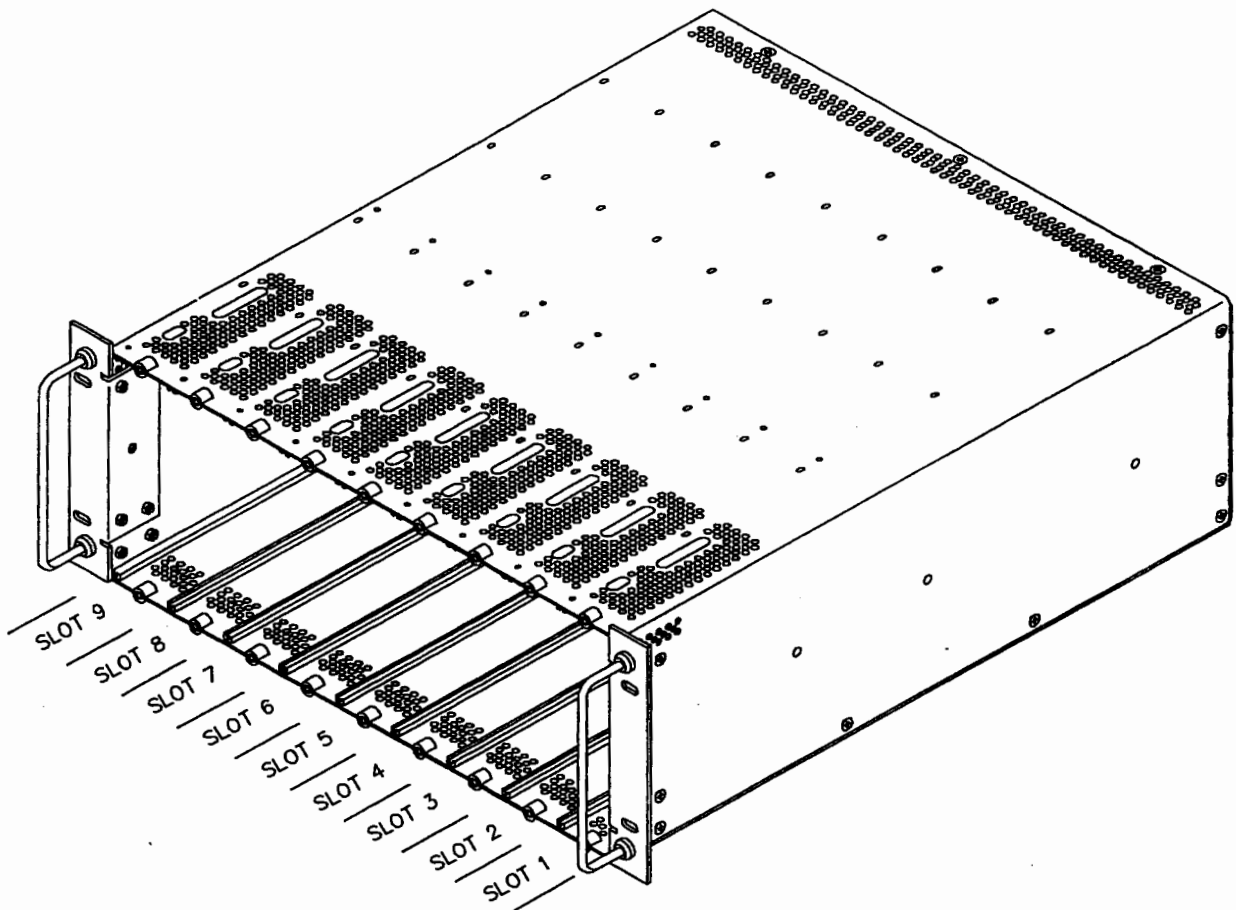
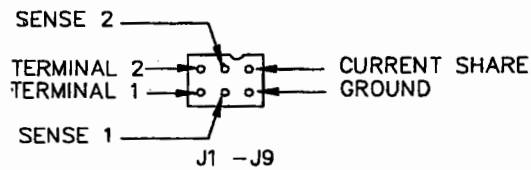
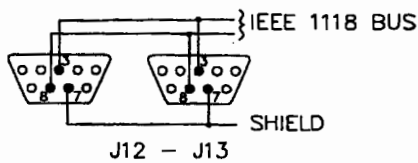
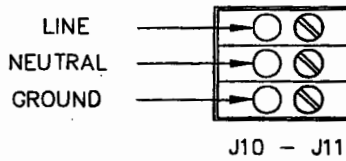
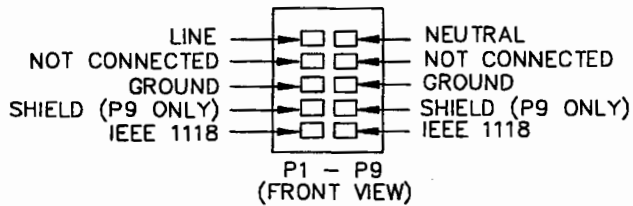
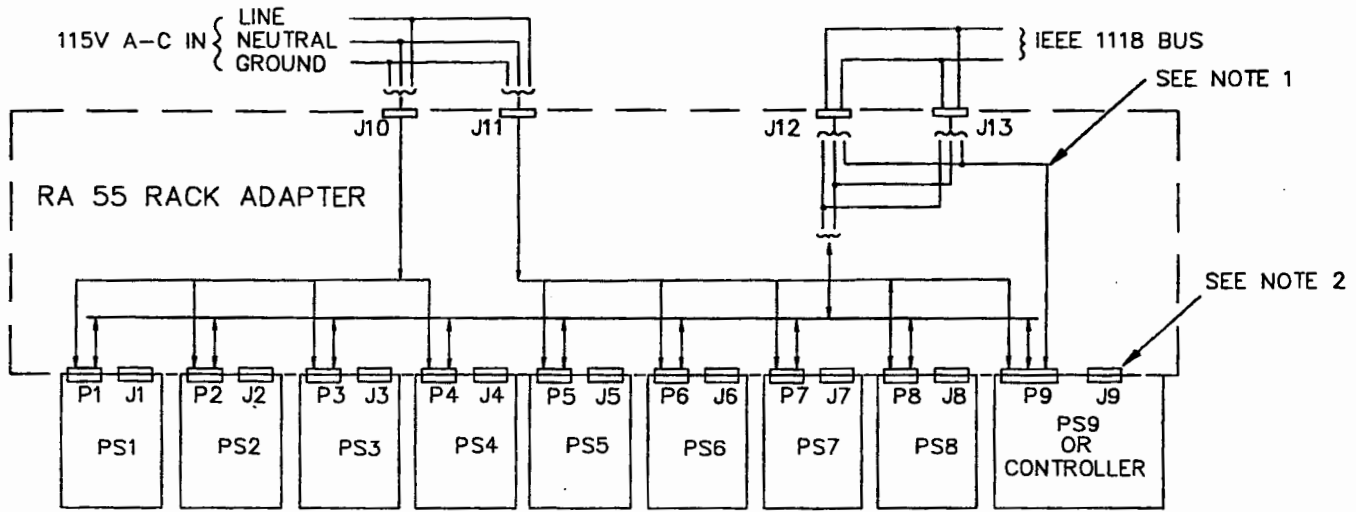

FIGURE 1. KEPKO MODEL RA 55 RACK ADAPTER



NOTES:

1. IF MST 488-27 CONTROLLER INSTALLED, SHIELD CONNECTED TO GROUND WITHIN CONTROLLER. IF PS9 INSTALLED, THIS LINE NOT USED.
2. J9 REMOVED IF CONTROLLER INSTALLED.

FIGURE 4. RA 55 INTERCONNECTIONS AND INPUT/OUTPUT PIN CONNECTIONS

an IEEE1118 Control Bus Terminator supplied with the Kepco controller ; even if only one Rack Adapter is used (for one rack, use either connector J12 or J13). Note that IEEE 1118 requires a daisy chain configuration only; other configurations (e.g., star) are not supported by Kepco.

**TABLE 1. ACCESSORIES**

ITEM	PART NO.	QUANTITY SUPPLIED
Connector Shell	Kepco - 142-0372 (Positronic Industries - MS112N)	9
Contact, 12 Gauge	Kepco - 107-0327 (Positronic Industries - PLB06M0050)	60
Cable (BIT bus, 2 meters long, with two 9-pin DSUB connectors)	Kepco - 118-0844	1
Terminator, IEEE1118 Control Bus	Kepco - 195-0086	(Supplied with Kepco controller)
Chassis Slide	Kepco 108-0249 (Jonathan 110-QD-18-2)	(Not supplied)

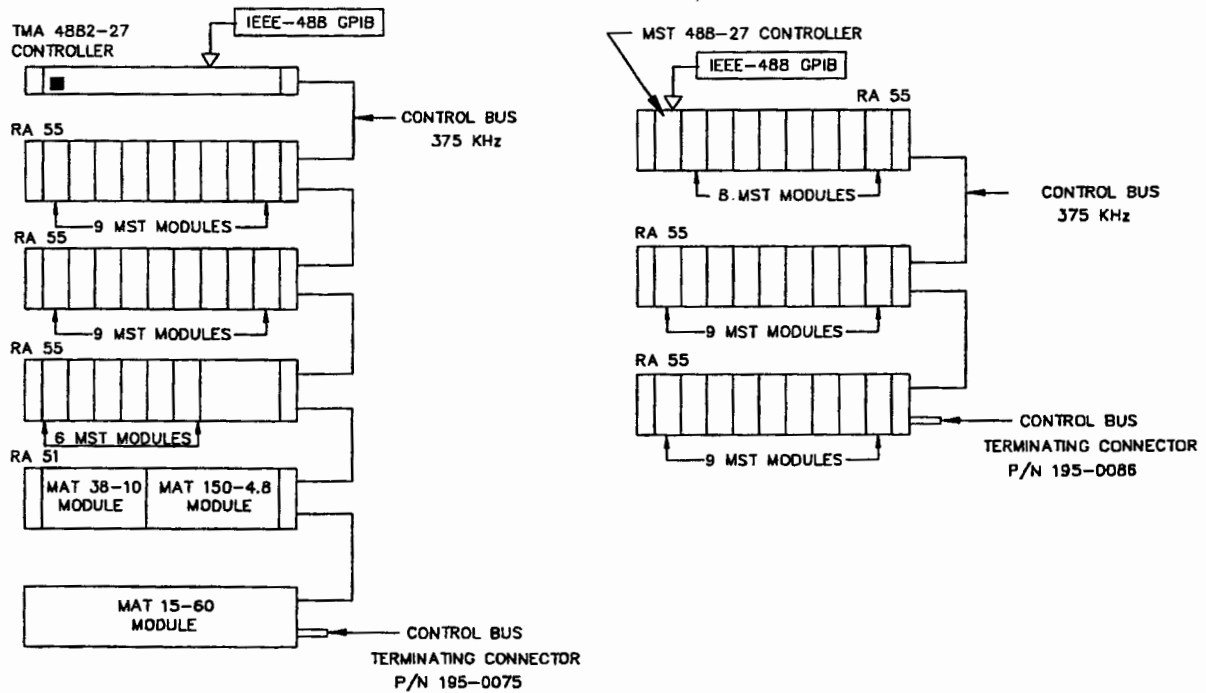

- NOTES: 1. MAXIMUM OF 27 UNITS CAN BE CONTROLLED (ANY COMBINATION)  
 2. TERMINATOR MUST BE CONNECTED EVEN IF ONLY ONE RACK ADAPTER USED.  
 3. CONFIGURATIONS OTHER THAN DAISY CHAIN NOT SUPPORTED.

**FIGURE 3. CONTROLLER TO POWER MODULE INTERFACE**

## SECTION 2 - CONFIGURING THE RA 55 RACK ADAPTER

### CAUTION

**RACK ADAPTER SHOULD BE MOUNTED AND FASTENED SECURELY TO RACK BEFORE INSTALLING POWER SUPPLIES TO AVOID DISTORTION OF THE RACK ADAPTER. ( INSTALL POPULATED RACK ADAPTER ONLY IF BOTTOM OF RACK ADAPTER IS FULLY SUPPORTED.) FAILURE TO OBSERVE THIS CAUTION MAY RESULT IN MISALIGNMENT OF THE POWER SUPPLIES WITH THE RACK ADAPTER.**

- NOTES:
1. Prior to installation of MST Power Modules, remove the two plates installed in slots 3 and 7 (see Figure 1) for support during shipping.
  2. If Rack Adapter is received with MST Power Modules already installed, each Power Module is secured to the Rack Adapter with two shipping screws. These screws are accessible from the bottom of the Rack Adapter, and must be removed before installing the Rack Adapter, otherwise the MST Power modules cannot be removed from the Rack Adapter.

### 2.1 INPUT POWER

#### 2.1.1 GENERAL

Interconnections between an a-c power source and a stabilized power supply, and between the power supply and its load, are as critical as the interface between other types of electronic equipment. If optimum performance is expected, certain rules for the interconnection of input power source, power supply and load must be observed by the user. These rules are described in detail in the following paragraphs. All interconnections are accomplished at the backplate assembly (Figure 2). Refer to Figure 3 for RA 55 interconnections and input/output connector pin assignments.

#### 2.1.2 SAFETY GROUNDING

National and international safety rules dictate the grounding of the metal cover and case of any instrument connected to the a-c power source. The instructions below suggest wiring methods which comply with these safety requirements; however, in the event that the specific installation for the power system involves differences with the recommended wiring, it is the customers responsibility to ensure that all local electrical codes for safety grounding are met.

#### 2.1.3 SOURCE POWER CONNECTIONS

### CAUTION

**THE RA 55 DOES NOT INCORPORATE ANY SAFETY INTERRUPT DEVICES. PROTECTION OF INPUT WIRING REQUIRES USER-CONFIGURED SAFETY INTERRUPTS.**

The backplate assembly of the RA 55 includes two 3-terminal terminal blocks (J10 and J11) to allow for the connection of single-phase source power. The connector positions are labeled L, N, and G. Their functions are as follows:

- **Terminal G (Ground)** is the safety ground connection for the RA 55, is connected to the RA 55 chassis and to the safety ground terminal of the input power connector for each of the nine mounting positions via the PCB backplane. Terminal G must be connected to safety ground in order to ensure proper grounding of the MST power supplies and MST 488-27 Controller (when installed).

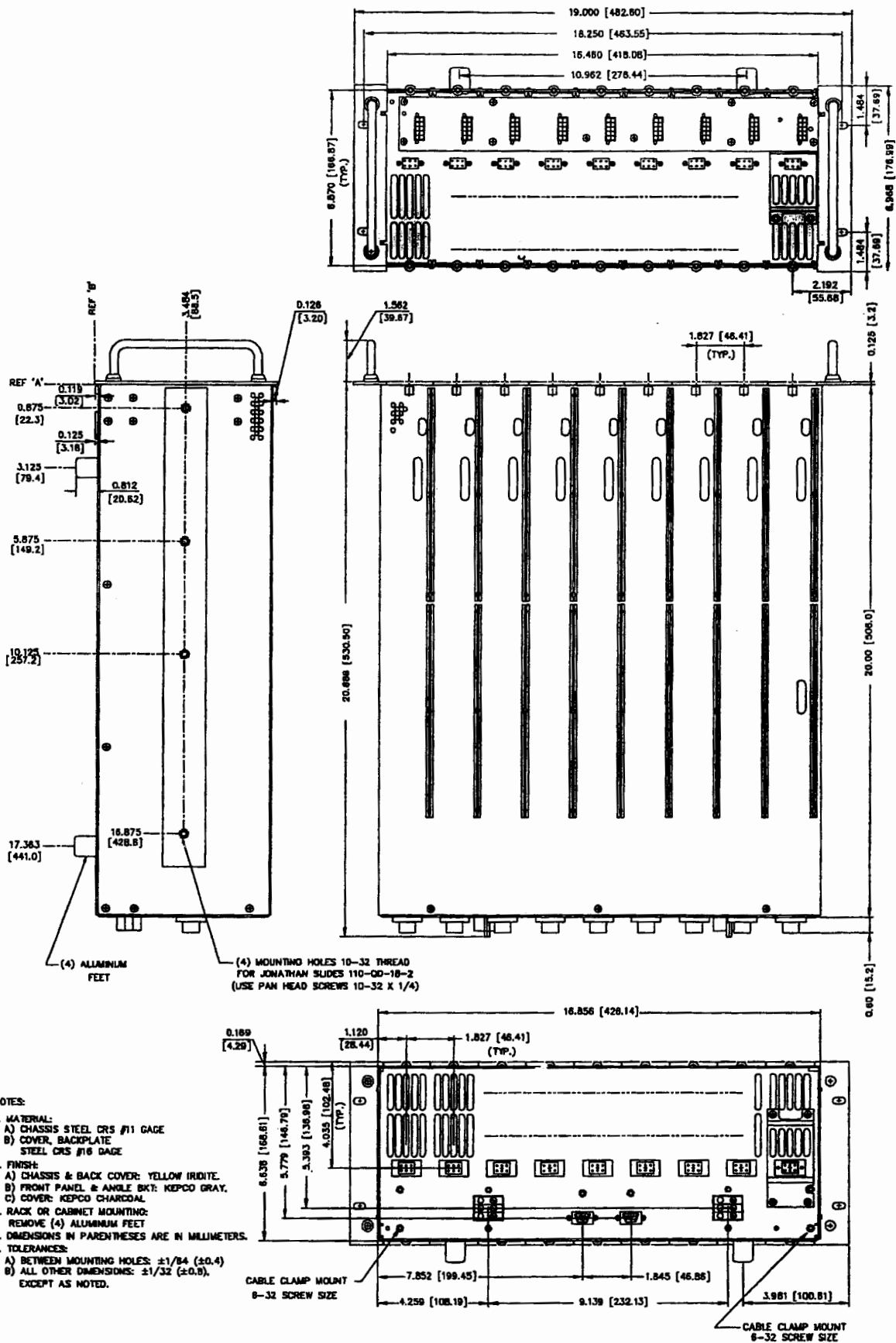
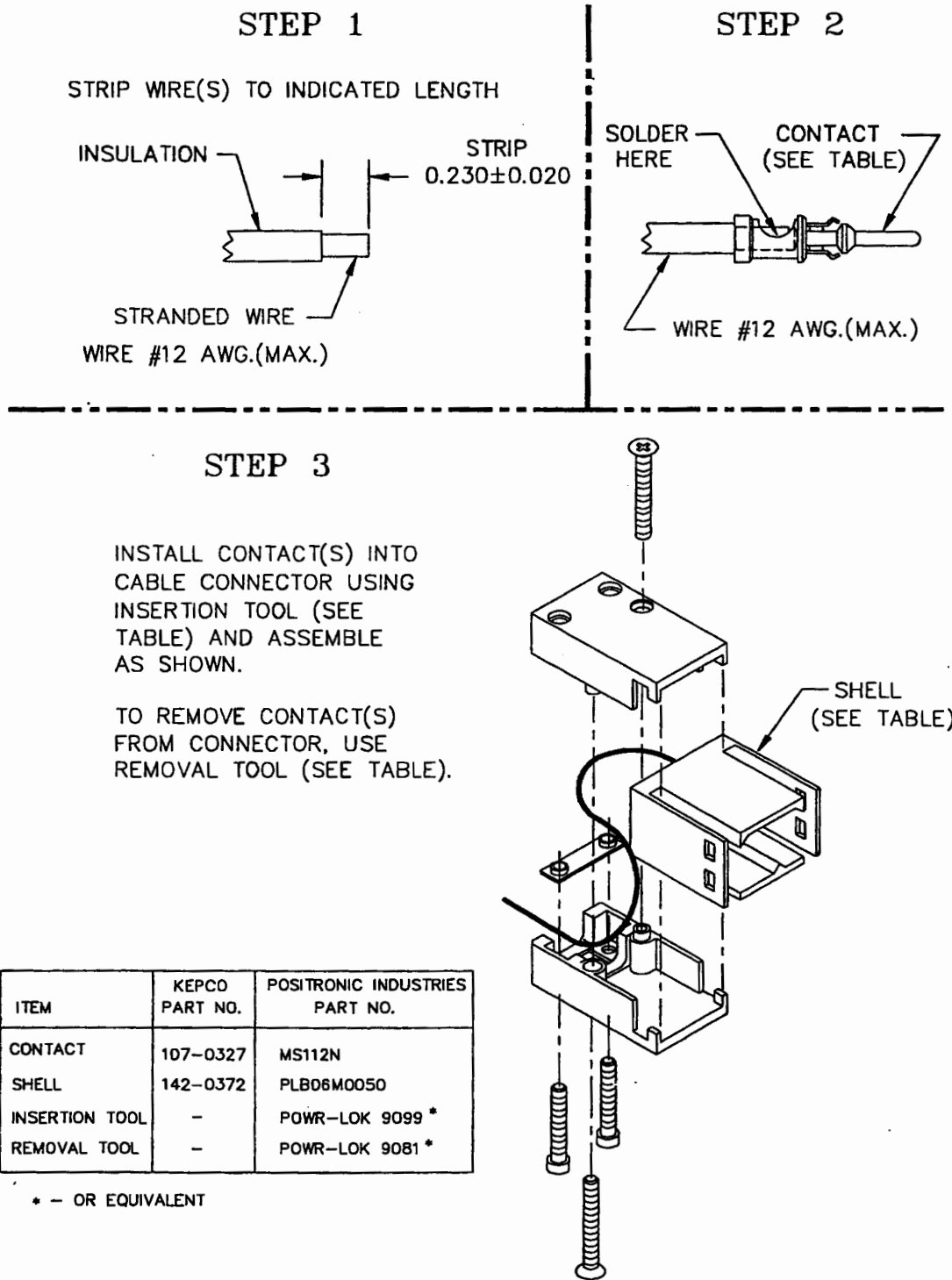

FIGURE 5. MECHANICAL OUTLINE DRAWING OF THE RA 55 RACK ADAPTER



**FIGURE 6. LOAD CONNECTOR ASSEMBLY PROCEDURE**

- **Terminals L (Line Phase) and N (Neutral)** are connected to the input power entry connectors. J10 provides a-c power to connectors P1 through P4; J11 provides a-c power to connectors P5 through P9. Connectors J10 and J11 are independent of each other, allowing the user complete flexibility in wiring for common or redundant input power configurations.

The following standard wiring configuration is recommended by Kepco as being compliant with applicable national and international safety standards. Please consult local electrical codes for wirecurrent ratings and other specific requirements:

- Connect Terminal G of the RA 55 input power terminal block (J10, J11) to safety ground
- Connect a separate wire pair from each side of the input power to the L/N terminal pair of the input power terminal block (J10 for slots 1 through 4, J11 for slots 5 through 9).
- Wire size is determined by the maximum rated source current for each MST power supply and the number of MST modules installed. Operation below 100V rms can result in source current in excess of 15A at terminal block J10 or J11. For this reason Kepco recommends use of #14 AWG wire (minimum) in fully populated systems. For lower system power configurations, smaller wire can be used; contact Kepco Applications Engineering for assistance.

## 2.2 LOAD CONNECTIONS

Load connections to the RA 55 are achieved via the nine individual connectors (J1 - J9) located on the backplate assembly directly behind each mounting position (see Figures 2 and 4). Mating connectors (assembly required) are supplied (see Figure 6).

### NOTE

**REGARDLESS OF OUTPUT CONFIGURATION, OUTPUT SENSE LINES OF MST POWER SUPPLIES MUST BE PROPERLY CONNECTED FOR OPERATION (REFER TO MST INSTRUCTION MANUAL).**

## 2.3 CONTROL SIGNAL CONNECTIONS

Access to the IEEE 1118 communication control bus for each power supply is provided via two 9-pin D-subminiature type connectors (J12 and J13) on the backplate assembly (see Figures 2 and 4). Two pins of each connector are used for the 2-wire control bus; the third pin is utilized when a controller is installed in slot 9, allowing the shield to be grounded within the controller.

## 2.4 SLOT 9 CONFIGURATION

The unit is shipped with slot 9 configured to accept an MST power supply. To install a controller in slot 9, remove J9 connector plate by removing four screws at the backplate assembly (see Figure 2).

**NOTE:** Before installing MST Power Module in RA 55 Rack Adapter, pull out the two captive thumb screws at the front of the Power Module and turn counterclockwise until the threads engage.





**B1281858**

**REVISIONS**

NO.	DESCRIPTION	DRAWN BY	CHECKED BY	APPROVED BY	DATE	DATE	DATE

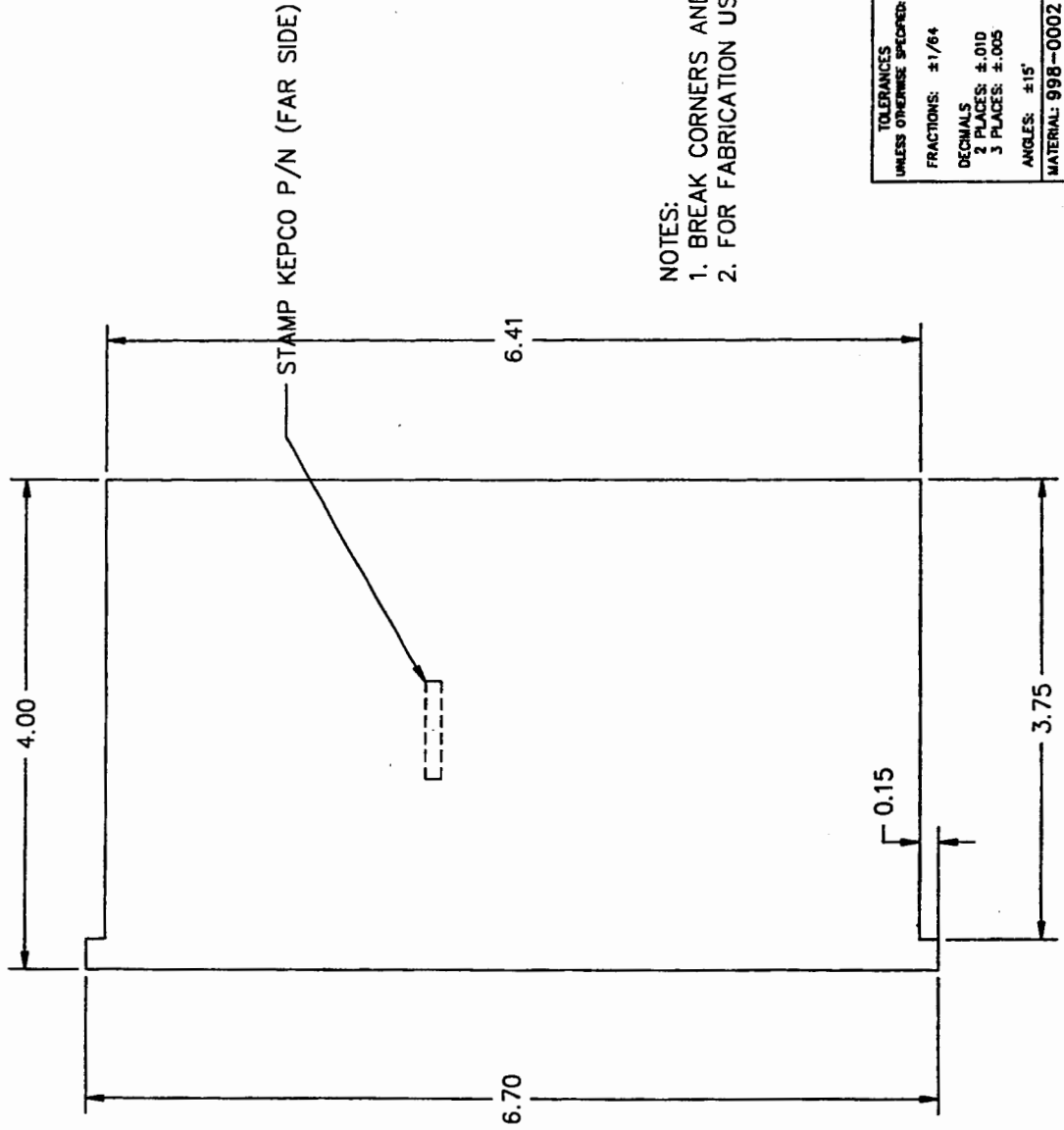

**NOTES:**

- 1. BREAK CORNERS AND SHARP EDGES
- 2. FOR FABRICATION USE FINGER STOP, SCRAP ALUMINUM STRIPS CAN BE USED

**TOLERANCES UNLESS OTHERWISE SPECIFIED:**  
FRACTIONS: ±1/64  
DECIMALS  
2 PLACES: ±.010  
3 PLACES: ±.005  
ANGLES: ±15°  
MATERIAL: 998-0002  
.064 THK ALUM.  
FINISH: NONE

DRAWN BY: MB  
CHECKED BY: [ ]  
DESIGNED BY: [ ]  
APPROVED BY: [ ]

DATE: 7-5-94



**FILLER PARTITION**

MODEL NO. RA 55  
PART NO. 128-1858  
SCALE: 1:1

DWG. NO. **B1281858**  
SHEET: /

